

# HIFICRITIC ARCHIVE IV

*This 1994 essay was tough on the audio industry for its uncritical promotion of the virtues of balanced operation. Based on contemporary experience, the picture can change with time and product improvement. See the ARC REF3 evaluation for Issue2 for an idea of progress in balanced preamplifier design.*

## Balance: Benefit or Bluff?

*Martin Colloms, November, 1994*

If you read much promotional literature for recently introduced high-quality equipment, you'll notice a common theme emerging: balanced connection. Balanced inputs and outputs are becoming a must for any audio equipment that has any claim to quality. The word itself has promotional value, suggesting moral superiority over the long-established "unbalanced" connection (for the purpose of this discussion, I will call this "normal"). What's my problem with this? Simply this: The High End could be paying dangerous, costly lip service to the received wisdom that balanced operation is the goal for an audio system.

To give you a flavour of the literature using balanced operation as a selling point, Audio Research's literature for their LS5 preamplifier describes "an imposing array of...professional-grade XLR connectors...clearly proclaims the fully balanced design...an uncompromising approach. While the professional industry and recording studio used balanced operation and connectors as a standard for many years, the consumer electronic industry is only now gradually adapting its products to this superior format."

In my view, unwarranted and unwanted assumptions are being made in the dissemination of such claims. I am not singling out Audio Research for criticism— at present this approach is rife.

A state of madness currently exists wherein several international markets are discriminating against some excellent audio equipment simply because it doesn't have balanced signal connections. This is madness; there's no reliable proof that an audio system

with balanced connections sounds any better than a well-designed normal system. In fact, time and again, top-line components that come my way for evaluation suggest no advantage—and in some cases, even demonstrate performance loss—for balanced operation.

Market pressures are so great that, much against their better judgment, a number of designers are succumbing to the demand for balanced equipment, passing the extra cost on to their customers. For example, I know of a fine D/A processor that delivers superb sound quality in its normal form. One of its primary virtues is its very short signal path following the DAC chip, which the designer refused to sully with the usual, compromised, tacked-on balanced output amplifier. To maintain sound quality in the market-mandated balanced form, the designer was driven to replicate the entire DAC chain, driving the second DAC with a non-invasive, inverted digital data signal in order to achieve the pair of audio outputs for balanced working. It almost doubles the cost of the decoder, with no perceptible audible benefit. [*However, it does lower DAC noise by 3dB, which some will feel a worthwhile increase in resolution, while the D/A processor's overall linearity can also be improved.—Ed.*] While this is an extreme example, there's no dispute that balanced designs generally cost more.

Many "balanced" products are single-ended inside with messy, potentially sound-corrupting conversion buffer/amplifiers at the inputs and outputs. Some components have more complex amplification stages in the minus line than in the plus. Only a few products are truly balanced from input to output, and then costs escalate. For example, a

true balanced preamplifier, such as the Audio Research LS5, needs a four-gang selector switch and a four-gang volume control, for the latter each section must be closely matched to the others.

### Normal vs. Balanced

I suspect many of us do not know what balanced operation is, other than that it involves a different kind of signal connector from the familiar RCA plug.

Audiophiles have lived with normal connections—two wires, respectively, for ground and signal connections—for decades without experiencing significant problems (figs.1 & 2). Even the requirements of those delicate low-level signals from moving-coil cartridges can be handled satisfactorily, provided that appropriate care is taken with local hum fields and system grounding. And with digital sources, the signal levels are so high that noise and hum are considered wholly negligible. If a normal, unbalanced connection can be made to work for a tenth of a thousandth of a volt signal from a low-output phono cartridge, it must be cast-iron reliable for the 1V or 2V signal from a modern digital source.

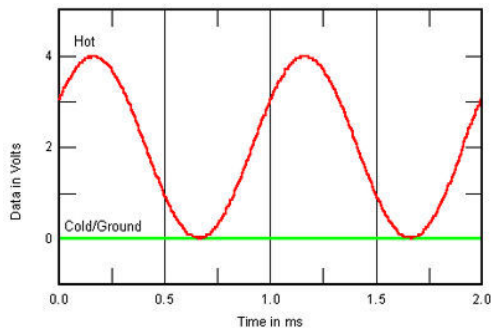
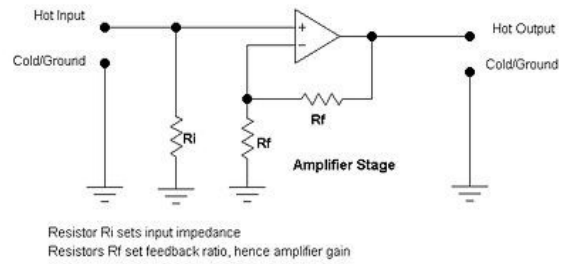

Fig.1 An unbalanced signal connection.



Resistor  $R_i$  sets input impedance  
Resistors  $R_f$  set feedback ratio, hence amplifier gain

Fig.2 A typical unbalanced amplifier input stage (which may be either discrete or in the form of an IC). For balanced working, the signal's positive-polarity connection (+, or hot) and negative-polarity connection (-, or cold) are segregated so that the - is no longer combined with the earth, shield, or ground line. Instead, a three-wire connection allows the ground line its own separate identity. The opposite-polarity + and - signal lines may then be said to be balanced, or set equal with respect to the ground (figs.3 & 4). This balance is not engineered for aesthetic or philosophical reasons, but so that the next input in the chain can be arranged to *measure* the *difference* between the two audio lines. Well-designed balanced inputs operate as differential circuits, and any unwanted noise, hum, or interference common to both lines is therefore cancelled (fig.4). The recovered signal is the difference between the hot and cold signals, and is therefore twice the level of either on its own, and is why substituting a true balanced connection boosts the level by 6dB compared with an unbalanced one, all things being equal.

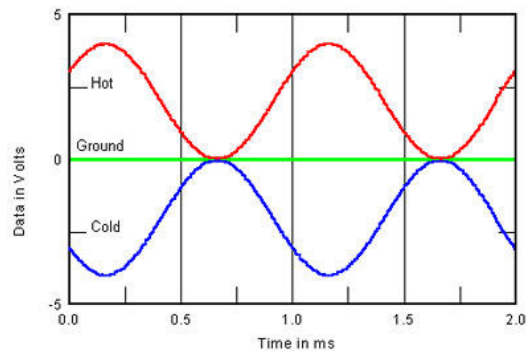

Fig.3 A balanced signal connection.

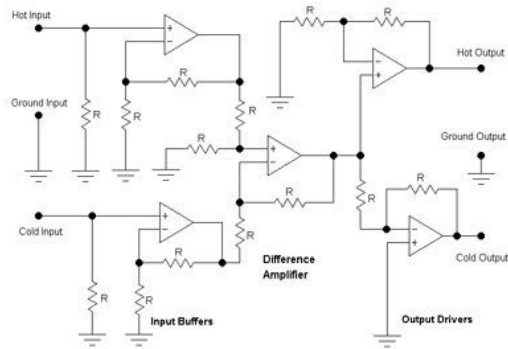

Fig.4 A typical all-balanced preamplifier line stage. The hot signal (H) consists of the wanted signal (A) plus noise (N);  $i.e.$ ,  $H=A+N$ . The wanted cold signal is A in antiphase,  $-A$ , and again the same noise picked up by the cable, N;  $i.e.$ ,  $C=-A+N$ . Because the noise is the same in both hot and cold lines, it is termed "common-mode" noise. Provided the amplifier's differential input has total common-mode rejection, it subtracts the cold signal from the hot, with an output  $D = (A+N)-(-A+N) = A+A+N-N = 2A$ . Note complexity compared with fig.1 circuit. In addition, the resistors marked "R" must be closely matched between hot and cold signal polarities to maintain common-mode rejection and minimize distortion.

This is a powerful and valuable technique when you need to use it. When a newscaster needs an audio connection from his or her mike to the producer's console three rooms away, the cable carrying the low-level signal may traverse power and control cable ducting for the building—typically a run of 30m or more. An effective means of low noise transmission is vital in this situation. Or, take a large orchestra at a recording session: local spotlight mikes may need 100m of cable to get to a remote mixing desk. Likewise consider crossed pair mikes hung from the auditorium ceiling for ambience pickup, these will need a long cable run. Long runs spell induced noise pickup.

If the high noise rejection levels possible with balanced operation are not required, then the technique's drawbacks come into focus—it adds complication, complexity, and cost to audio components. Disciples of short-path design know only too well how each additional stage can potentially step you down the fidelity ladder.

So consider the arguments for and against balanced design for high-quality consumer audio components:

#### For:

- 1) High electrical noise immunity to both induced signals (Radio Frequency and Electromagnetic Interference, RFI and EMI) and also chassis ground-hum loops.
- 2) Essentially transient free, hands-on cable connection; with the ground made first, contact transients are suppressed.
- 3) Standardized XLR connectors are mechanically self-locking; make good, gas-tight contacts to a specified close tolerance; and generally have good cable strain-relief fittings.
- 4) With balanced cable, the + and - signal paths are equal;  $i.e.$ , they use the same conductor type, which improves the potential for good cable sound.
- 5) Effective over very long runs—greater than 60'—and/or for very-low-level signals of very wide dynamic range, such as those from microphones.
- 6) Professional and broadcast studio use implies quality by association.
- 7) Safety requirements for effective chassis grounding can be easily met.
- 8) Encourages good practice for low electromagnetic radiation and good immunity.
- 9) For the digital interface, it provides a beneficially higher signal operating level.

#### Against:

- 1) Greater cost.
- 2) Greater extent and complexity of audio circuits.
- 3) May results in matching difficulties with existing normal single ended equipment.
- 4) a fairly restricted choice of cables.
- 5) Restricted choice of connector grades; the best XLR types are technologically inferior to the best, albeit costly, RCA plug types, though the average XLR is undoubtedly superior to the average RCA
- 6) Partial disagreement between Europe and the US over pin code connections.

7) No guarantee of superior sound to well designed unbalanced systems.

### Skirmishes

Although my primary reference system is not balanced, until recently I've gotten by without serious trouble. I've had many skirmishes with balanced equipment, but I've been able to supplement my few balanced reference audio components with validated, current-review loan stock as and when required. However, when I was asked to review the Audio Research LS5 line preamplifier and its matching PH2 phono preamp ( *Hi-Fi News & Record Review*, February 1994, Vol.39 No.2, pp.30-35), I was brought face to face with the full implications of true balanced operation.

---

All the usual mixing and matching review procedures were useless; it was out of the question to make direct comparisons with other unit audio components.

The evaluation proved to be a fight every inch of the way, precisely because these Audio Research components are of true balanced design; *ie*, fully balanced differential circuitry is present at their every stage, including cross-coupling between hot and cold signal paths. It didn't take me long to realize that you can't mess with true balanced components; fully balanced connections, in and out, is all that will be tolerated if satisfactory hum and hiss performance is to be obtained. With the ARC equipment, this meant that comparison with normal phono equalizers and line controllers was almost impossible. If I didn't know better (and perhaps I don't), I could be persuaded that the closed and self-perpetuating circle generated by wholly balanced systems is a deliberately constructed barrier raised against the true comparative assessment of their subjective quality.

For example, take an Audio Research V-series power amp with its balanced input (again, I'm not singling out ARC). In my experience, it won't perform at its best unless it's driven balanced. If you want to hear this amplifier in an unbalanced system, then I strongly advise you to acquire the relevant unbalanced/balanced converter, the Audio Research BL1. Regardless of the latter's exceptional quality, you've necessarily added a second set of connectors, cabling, grounding, and expense.

Yes, it's true that operating the amplifier with a high-quality balanced control unit, such as the LS5, facilitates evaluation of the amplifier—that is, assuming that you're totally familiar with the balanced preamp's quality. If not, you may have to check it out by turning to your favourite digital source, which, again, most likely will have "normal" outputs. You therefore have to bring another unbalanced/balanced converter into action, again resulting in an unwanted step in the chain.

### Cautious words

Enough examples. With no disparagement intended against the fine Audio Research products mentioned above, my experience with balanced components has been that they're not necessarily better than normal components. Indeed, they can often sound better via their subsidiary "normal" signal connections. Enough equipment has passed through my test setup that I feel comfortable making a few cautious generalizations.

True, the balanced condition does result in lower noise levels and improved immunity to EMI and RFI, local ham radio, CB operators, or switching pulses from heating or refrigeration thermostats. On the debit side, stereo images may lose absolute focus, stage width, and depth. Sounding less "locked in" to the music, some balanced audio components often exhibit losses in dynamic resolution, dynamic contrast, and rhythm. Typically smooth-sounding and laid-back, a balanced component can be less involving, lending the music a "downbeat" impression.

This essay shouldn't be seen as a write-off of *all* balanced components. The differences I have discussed are not huge, though the differentiation of such differences are partly what the High End is, or should be, about.

Interestingly, the characterizations I mention are also those associated with less-than-first-rate connectors. Taking this together with the necessary additional circuit complexity required by balanced operation, these factors together make some sort of sense. Something as simple and direct as a Conrad-Johnson Premier Eleven power amplifier—a "normal" input design—probably couldn't be built in balanced form without compromising its engineering purity *and* its sonic purity.

### **Grounding 'n' timing**

There's an element of circuit philosophy that's relevant here: In my experience the most dynamic sounding, best-timed audio systems have fundamentally good system grounding. I don't mean just the chassis ground paths. We have to consider that the signal ground is defined as a true reference point, carefully organized, even to the extent of a hierarchy of grounds focused at a single star point. These grounds are scaled and organized according to their role and the signal section they serve. Such organization, if successfully effected, can endow the system with a fine sense of poise and equilibrium, if I may put it this way, with the sound set firmly on the 'ground' rather than precariously "balanced" above it.

Once a fast, well-tuned audio system has been set up, it's fascinating to observe how quickly and catastrophically its sound can be made to fall apart subjectively, piece by piece, as the main structure of the electrical organization and grounding is progressively disturbed or dismembered. In one highly tuned example, a sophisticated audio system featuring active crossovers had been set up in every detail save the AC mains supply. I was worried about its conspicuous failure to perform properly—the just "improved" system actually sounded less musical and entertaining than the simpler passive implementation of the same components, used with lower-grade power amplifiers.

Seeking guidance, I was advised that, in addition to the centralized, focused grounding so carefully designed for this system's signal paths, the AC connections must also be similarly centralized. Although I was using a pair of high-quality, dedicated AC lines, the multiplicity of system power cables necessitated the use of multi-way socket strips. Accordingly, I detached all the AC plugs and compression-bonded all the 10A-rated IEC power cords to a 30A terminal block, this in turn was plugged-in to one high-current spur on the AC mains supply.

In this critical context the sonic transformation seemed little short of amazing. A whole spectrum of audible changes occurred. For example, a previously heard degree of midrange glare and harshness was sufficiently reduced that it could now be accepted as a normal part of the tonal balance. Stereo focus and depth were improved. Treble grain and roughness were smoothed out, while bass took on a new dimension of depth, solidity, and dynamic slam. Previously, this system had

conspicuously fallen short in rhythm and dynamics. Now these were to a reference standard.

### **A question of balance**

At the leading edge of today's high-end audio, the overall quality of an audio replay system is known to show a strong sensitivity to overall design and organization: in particular, issues of interconnect cable choice, grounding, and power supplies. In theory, balanced operation should free audio systems from such dependencies.

In practice, however, the consequences of such freedom appear to be losses in absolute sound quality, particularly in the areas of "foot-tapping" involvement and dynamics. Perhaps there's a lack of rigor and critical assessment in the design of balanced components. Maybe good performance is taken for granted. The adaptation to balanced working is unwittingly used as a problem-solving crutch; the technological benefit obviously lies in easily produced, impressive specifications for signal/noise. But what about sound quality? We still cannot adequately measure that.

I consider that the industry should take a critical look at this headlong rush to balanced systems, weigh the costs, and be honest about the advantages, if any to the home consumer. Most importantly, audiophiles must be objective about changes in sound quality. Balanced mode may turn out to be a fashionable whim—a device to promote sales—and may not add significant musical value even at the highest quality level.

end